



PRODUKT DATASHEET

WEATHERLITE

PRODUCT DESCRIPTION:

The Colt base system (shown here with the Weatherlite and Colt ECO smoke and heat exhaust ventilation unit) is made from a low-maintenance, lightweight aluminum construction. It includes aerodynamically shaped internal side flaps that open once the ventilation/SHEV unit closes, allowing the system to function reliably even in rainy conditions.

PRODUCT APPLICATION:

Typical applications include industrial and public buildings. The Weatherlite is used wherever continuous, rainproof ventilation is needed.

PRODUCT FEATURES:

- High-volume ventilation even in bad weather -
- Continuous ventilation with weather protection -
- Night-time cooling - Smoke and heat extraction in case of fire (when combined with mounted SHEV unit) -
- Natural daylight entry - Suitable for both new builds and retrofits

Product Description

The Colt Weatherlite base system provides rainproof ventilation and is made from a low-maintenance, lightweight aluminum construction. Aerodynamically shaped internal side flaps are integrated into the unit. These open once the mounted ventilation or SHEV unit closes, allowing reliable ventilation even during rainfall.

CONTROLS

The system can be operated using two pneumatic cylinders or 24 V / 230 V motors – suitable for both new installations and retrofits.

In rainy conditions, the motor or cylinders open the internally sealed flaps (equipped with rubber gaskets). In fair weather, the flaps close, and ventilation switches back to the mounted ventilators. This ensures reliable, rainproof ventilation at all times.

BASE

The base is available in either a single-skin or double-skin insulated version. The insulation consists of rigid polystyrene foam panels, with a U-value of 1.19 W/m²K and a thermal conductivity (λ-value) of 0.035 W/mK.

The Weatherlite can be installed on roofs with slopes up to 45°.

Dry Weather Ventilaton

SHEV unit open /
internal flaps closed*

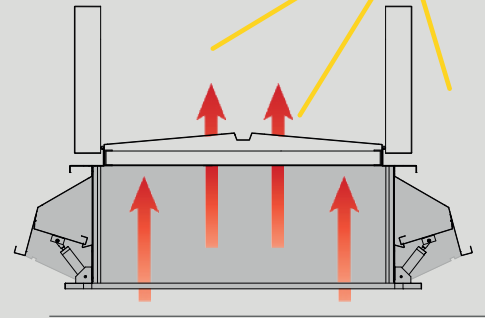

Smoke and Heat Exhaust

SHEV unit open /
internal flaps closed*

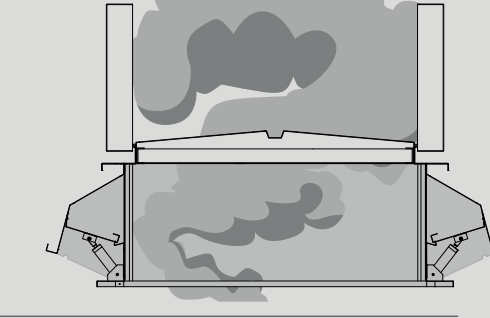

Winter Weather

SHEV unit closed /
internal flaps closed*

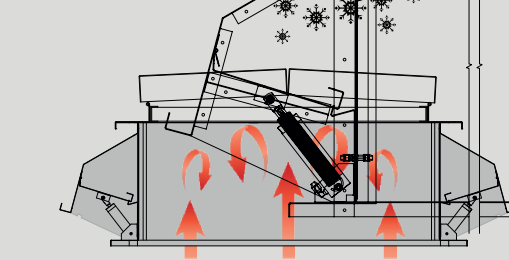

Ventilation During Rainfall

SHEV unit closed /
internal flaps open*

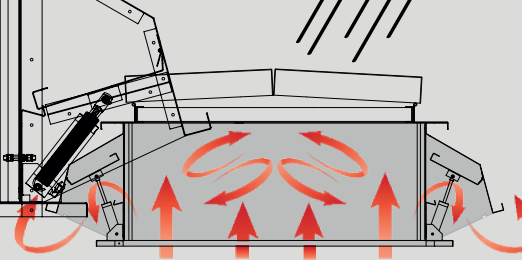

*Images show the Colt Apollo SHEV unit. The Weatherlite is compatible with all Colt SHEV flap and louvre ventilators.

KEY FEATURES

Available in variable mm increments

Also available in insulated versions for improved U-values

High Cv value of up to 0.45 for the internal flaps

Base height: 550 mm

High rated building sound insulation of 14 dB in the open position, without additional silencers

Smoke and heat extraction in the event of fire

Reliable, weatherproof continuous ventilation 24/7

Desirable night-time cooling

High-volume ventilation even in bad weather

OPENING WIDTHS AND LENGTHS

Neck opening width B: min. = 400 mm / max. = 3000 mm

Neck opening length L: min. = 500mm / max. = 3500mm

*Dimensions depend on the device mounted above the Weatherlite

LONGITUDINAL SECTION

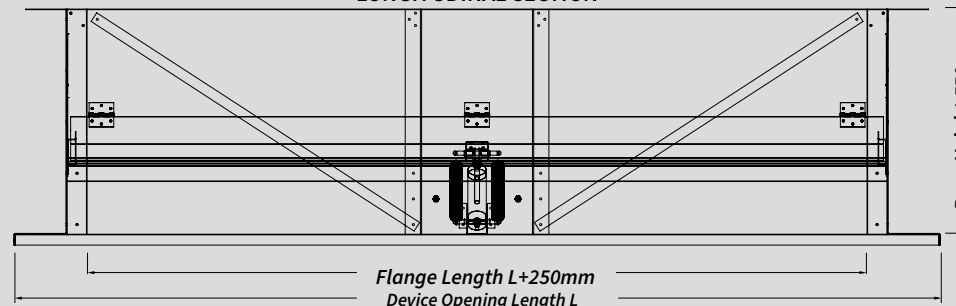

CROSS-SECTION

